

Fits following cars:
 Golf5 / Jetta5 / Audi TT2/ A3
 2.0T / R32 (Not Rabbit)
 (Not 2009>on 2.0T)

**VW / AUDI type 5 chassis Engine Side Mount (US-Passenger side).
 4 / 6 CYLINDER MODELS**

Fitting notes:

- 1) **WARNING: DO NOT LOOSEN OFF ENGINE MOUNTING BOLTS IF ENGINE IS NOT SUPPORTED FROM BELOW.**
- 2) **IF YOU ARE INSTALLING BOTH SIDE MOUNTS: ONLY INSTALL ONE SIDE MOUNT AT A TIME. THIS PREVENTS MISALIGNMENT OF THE ENGINE IN THE LEFT-TO-RIGHT AXIS.**
- 3) Support engine from below. Loosen off and remove the Engine side mount. Note: the black sheet metal brace is re-used together with its bolts.
- 4) Fit the new VF mount exactly in place of the original mount. All holes should line up and using new bolts secure mount and torque as below.
- 5) The VF mount is provided with a black brace: secure this to the underside of the factory brace which is mounted to the body of the car. The two braces can be bolted together by re-using the original 8mm bolt and 6mm stud which should also be used to secure the power steering reservoir.
- 6) Check torque settings after 200 miles. IF IN DOUBT CONSULT WORKSHOP MANUAL / VF-TECHNICAL. DO NOT INSTALL THIS PART WITHOUT USING A TORQUE WRENCH. DO NOT MODIFY THIS PART. CONSULT VF-ENGINEERING IF YOU HAVE ANY QUERY.

Bolt 1 - Mount to Body bolt 40Nm (30 ft-lbs)
 Bolt 2 - Mount bracket to body bolt 25Nm (18 ft-lbs)
 Bolt 3 - Mount to engine bracket bolt 60 Nm (44 ft-lbs)
BOLT IN CENTER OF VF-MOUNT TO BE TORQUED TO 40Nm (30 ft-lbs)

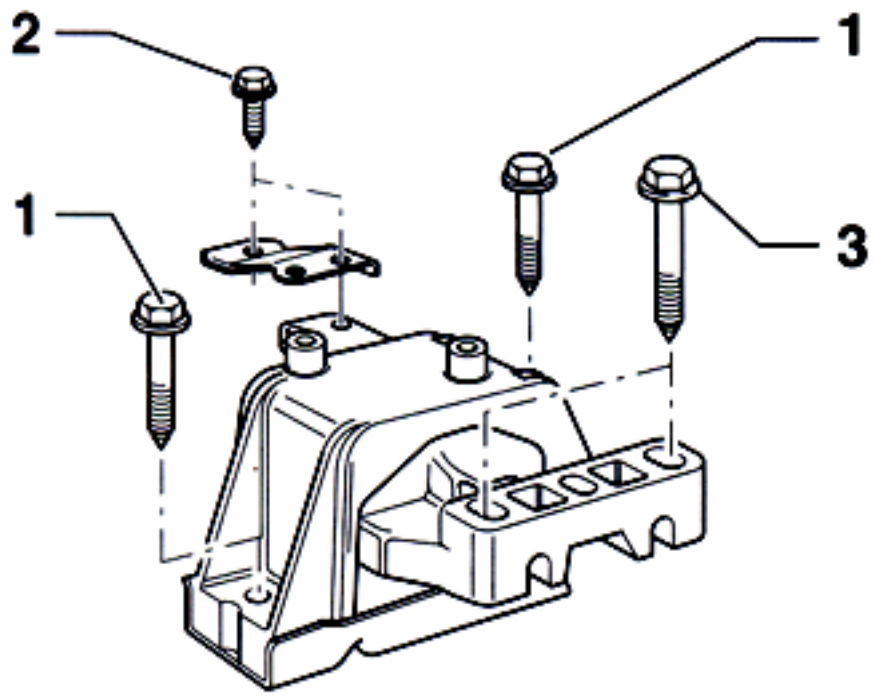

Warranty: 12 months or 12,000 miles whichever occurs sooner on defective VF parts only. No liability is accepted for consequential damage/ cost, misused or misfitted parts. For off-road use only. If in doubt do not fit part and consult retailer.

	MANF BY	Zurich Engineering, Inc.
	12 JUL 06	
TOLERANCE		www.vf-engineering.com
DRAWN	MFG ENG	VF PART #VFA06-02 /03

THE PRODUCT AND INFORMATION SUPPLIED IS THE SOLE PROPERTY OF ZURICH ENGINEERING, INC. ANY REPRODUCTION IN PART OR WHOLE WITHOUT THE WRITTEN PERMISSION OF ZURICH ENGINEERING, INC. IS PROHIBITED.